

NOWITECH final event 22-23 August 2017

Tuesday, 22 August, Session 15:30-16:35

Operation and Maintenance

Thomas Welte

SINTEF Energy Research
Thomas.Welte@sintef.no

Jens K. Jørgensen

SINTEF Materials and Chemistry
Jens.K.Jorgensen@sintef.no

WP B – Operation & Maintenance and Materials

Maintenance strategies

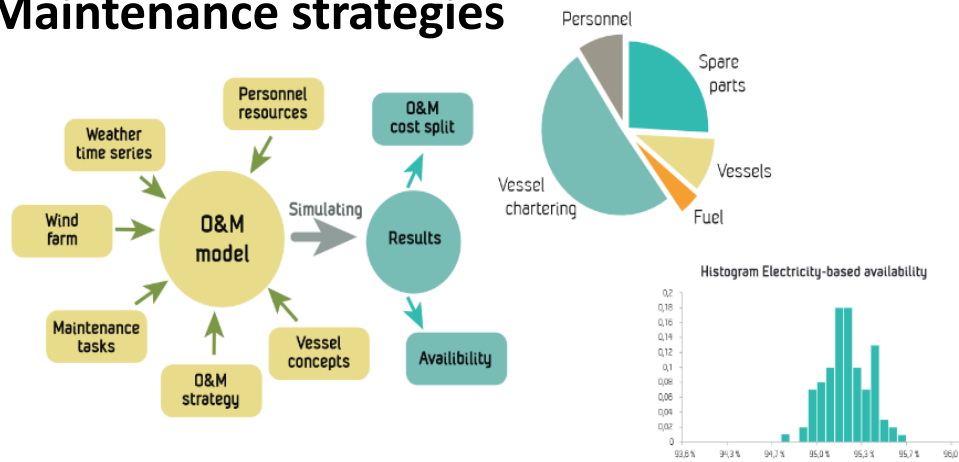

Surveillance and condition monitoring

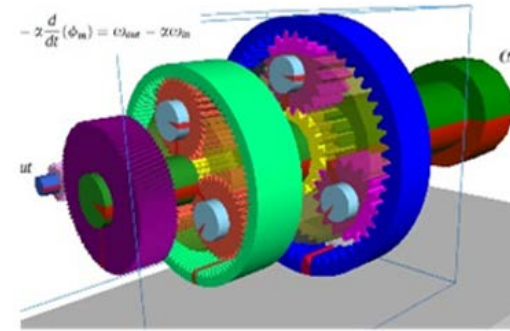

O&M

Rotor blade structures & materials

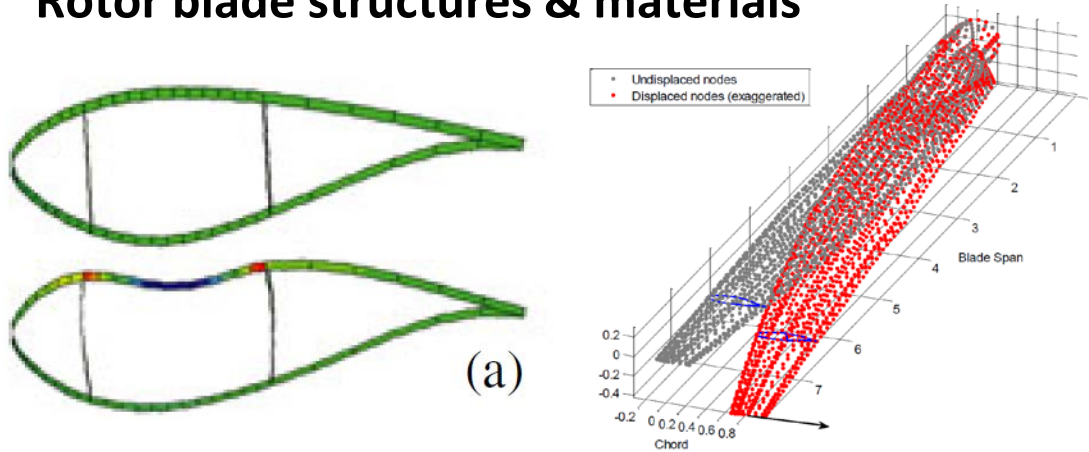

New coatings for better performance



Reinforced polyurethane



Materials

O&M and Materials - Innovations

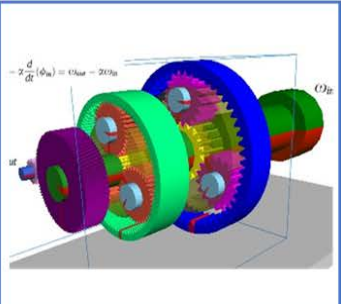

Gearbox fault detection
TRL3

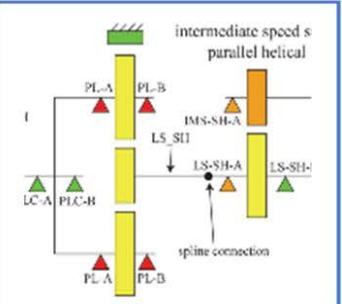

Gearbox vulnerability map
TRL3

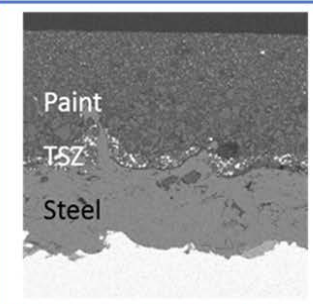

Dual layer corrosion protection coatings
TRL5

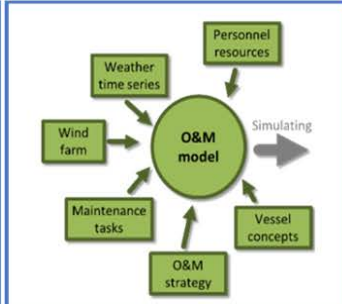

NOWIcob
TRL6

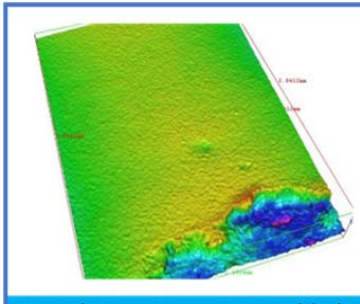

Droplet erosion resistant blade coatings
TRL3



Droplet erosion testing
TRL5



Remote Presence
TRL5

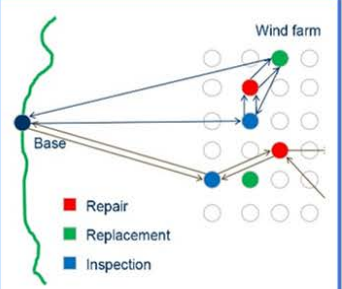

Routing and scheduling
TRL2



Thermally sprayed SiC coatings
TRL5

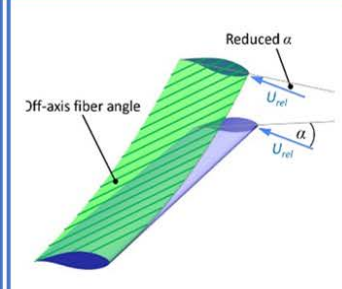

Buckling resistant blades
TRL3

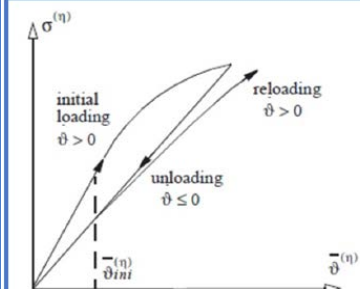

Fatigue damage simulation
TRL4



Fleet optimization
TRL5